

THIS PRODUCT CONTAINS PROPRIETARY INFORMATION OF OCP GROUP INC. AND IS SUBJECT TO THE CONDITIONS THAT THE INFORMATION: (A) BE RETAINED IN CONFIDENCE, (B) NOT BE PRODUCED OR COPIED IN WHOLE OR IN PART, © NOT BE USED INCORPORATED IN ANY PRODUCT EXCEPT ON AN EXPRESS WRITTEN AGREEMENT WITH OCP GROUP INC.

**REVISIONS**

DATE	REV	ECN	DESCRIPTION	APP'D
04/06	A	--	INITIAL RELEASE	MC
10/08	B	3387	REVISE DRAWING FORMAT ACCORDING TO MFG	MC



**ORDERING INFORMATION**

**12-10011-XX**

length:  
 .3 = 3 meters  
 1 = 1 meters  
 2 = 2 meters  
 3 = 3 meters  
 5 = 5 meters  
 7 = 7 meters  
 10 = 10 meters

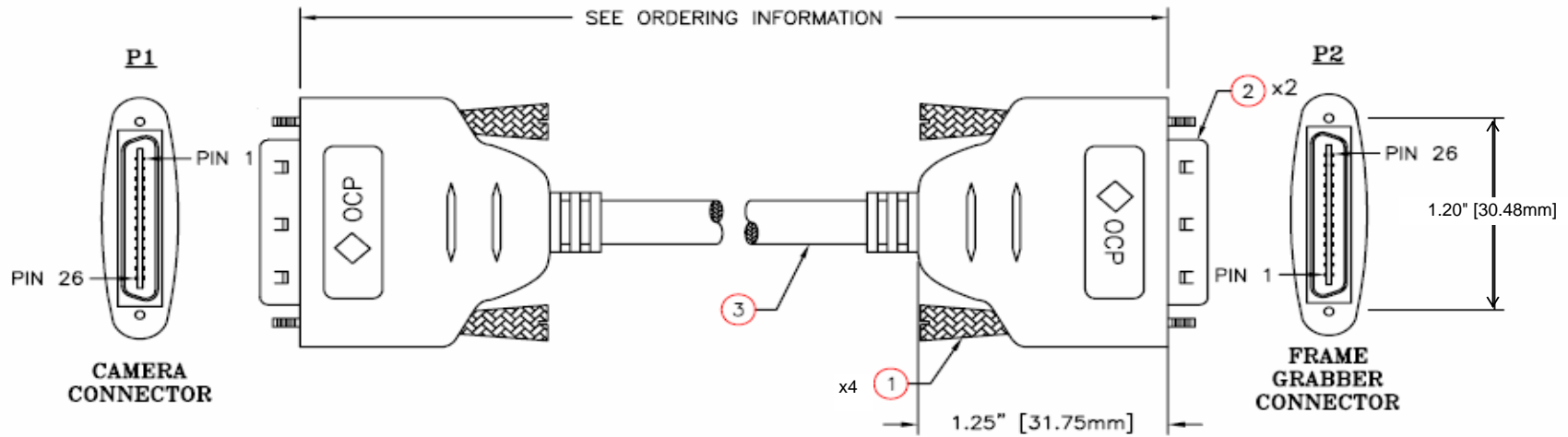

6			UNLESS OTHERWISE SPECIFIED			<b>TITLE:</b> CAMERA LINK CABLE, MOLDED				
5		<b>CABLE TOLERANCE</b>								OCP PART No.: SEE ORDERING INFO.
4			Length ± 3%				<b>CUSTOMER:</b> TBD			
3	CUSTOM ENGINEERED "CAMERA LINK" CABLE	A/R			SCALE: NTS	DATE: 09/02/08				
2	HALF PITCH 26 2-PL. POS. CENTRONICS CONNECTOR	2	<b>CONN. TOLERANCE</b>		UNITS: METER	CHK'D: CJG	A	12-10011-XX	B	1 OF 2
1	4-40 BLACK ANODIZED THUMBSCREWS, SLOTTED ENDS, KNURLED FINISH	4	Dimension ± 3%		DRAWN BY: ENG	APP'D: MC				
<b>ITEM</b>	<b>DESCRIPTION/REMARKS</b>	<b>QTY</b>								

THIS PRODUCT CONTAINS PROPRIETARY INFORMATION OF OCP GROUP INC. AND IS SUBJECT TO THE CONDITIONS THAT THE INFORMATION: (A) BE RETAINED IN CONFIDENCE, (B) NOT BE PRODUCED OR COPIED IN WHOLE OR IN PART, © NOT BE USED INCORPORATED IN ANY PRODUCT EXCEPT ON AN EXPRESS WRITTEN AGREEMENT WITH OCP GROUP INC.

**REVISIONS**

DATE	REV	ECN	DESCRIPTION	APP'D
04/06	A	--	INITIAL RELEASE	MC
10/08	B	3387	REVISE DRAWING FORMAT ACCORDING TO MFG	MC

**WIRING SCHEMATIC**

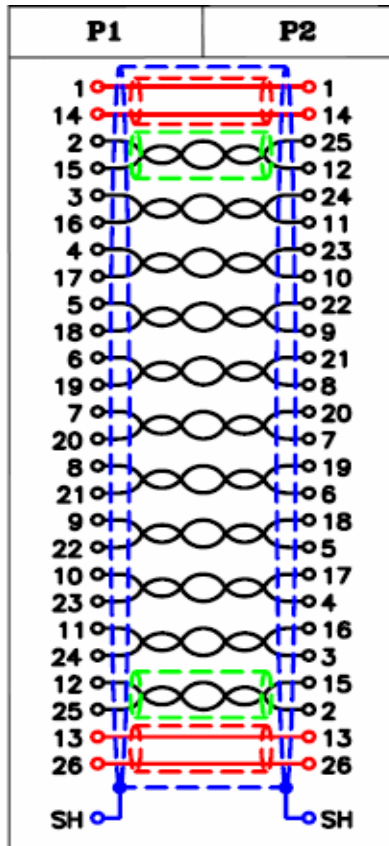

1. All pairs are individually shielded with aluminium foil.
2. Pair shields are wrapped aluminium out and are in contact with four internal drains.

**COMPONENTS**

**OVERMOLD** Low density Polyethylene and Polyvinyl Chloride (PVC), Color Black

**CABLE** HIFlex Clear Vu Camera Link, Jacket Color: Gloss Black  
Cable is constructed for continuous, high flex applications.

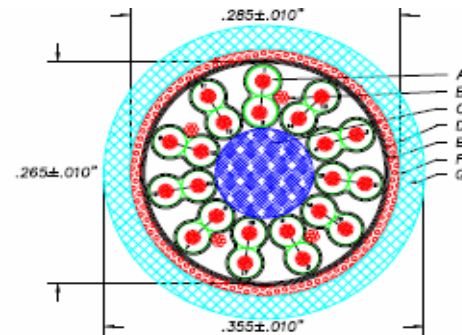
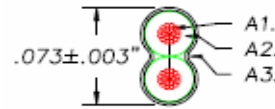

**A. SUB ASSEMBLY A**

- A1. 28 AWG 19x40TC UNILAY O.D. 0.01±0.001"
- A2. 8 MIL FOAMED POLYETHYLENE INSULATION  
7MIL MIN. FOAMED POLYETHYLENE INSULATION  
O.D. 0.035±0.001" 80°C 30V STYLE#1589
- A3. ALUMINIUM MYLAR SHIELD (25% OVERLAP)

**B.** 28 AWG 7X0.005"TC CONCENTRIC DRAIN (TOTAL OF 4)  
O.D. 0.015±0.001"

**C.** POLY FILLER

**D.** OPAQUE MYLAR WRAP (25% MIN OVERLAP 100% COVERAGE)  
**E.** ALUMINIUM MYLAR FOIL FREE EDGE SHIELD (FOIL OUT)  
(25% MIN OVERLAP 100% COVERAGE)

**F.** 36 AWG TC BRAIDED SHIELD (90% MINIMUM COVERAGE)

**G.** 30 MIL TUBED PVC JACKET 80°C 30V 24 MIL MIN. TUBED PVC JACKET

**ELECTRICAL**

**CONNECTION RES.** ≤5.0 Ω  
**INSULATION RES.** >5.0 MΩ  
**TWIST PAIR TEST**

**ENVIRONMENTAL**

*Cable Assembly is RoHS Compliant*

6			UNLESS OTHERWISE SPECIFIED			<b>TITLE:</b>			
5			<b>CABLE TOLERANCE</b>			CAMERA LINK CABLE, MOLDED			
4			Length ± 3%			OCP PART No.: SEE ORDERING INFO.			
3	CUSTOM ENGINEERED "CAMERA LINK" CABLE	A/R		SCALE: NTS	DATE: 09/02/08	CUSTOMER: TBD			
2	HALF PITCH 26 2-PL POS. CENTRONICS CONNECTOR	2	<b>CONN. TOLERANCE</b>	UNITS: METER	CHK'D: CJG	SIZE	DRAWING NUMBER	REV	SHEET
1	4-40 BLACK ANODIZED THUMBSCREWS, SLOTTED ENDS, KNURLED FINISH	4	Dimension ± 3%	DRAWN BY: ENG	APP'D: MC	A	12-10011-XX	B	2 OF 2
<b>ITEM</b>	<b>DESCRIPTION/REMARKS</b>	<b>QTY</b>							